



6LY400 / 6LY440

| | | | |
|------------------------------------|---|---------------------|-----|
| Configuration | In-line 6-cylinder, 4-stroke, vertical, water-cooled diesel engine | | |
| Maximum output at crankshaft | *294 kW@3300 rpm | [400 mhp]@3300 rpm | |
| | *324 kW@3300 rpm | [440 mhp]@3300 rpm | |
| Displacement | 5.813 L | [354 cu in] | |
| Bore x stroke | 106 mm x 110 mm | [4.17 in x 4.33 in] | |
| Combustion system | Direct Injection with Denso Common-Rail system | | |
| Aspiration | Turbocharged with watercooled turbine housing | | |
| Starting system | Electric starting 12V - 2.5 kW | | |
| Alternator | 12V - 125A | | |
| Cooling system | Fresh water cooling by centrifugal fresh water pump and rubber impeller seawater pump | | |
| Lubrication system | Enclosed, forced lubricating system | | |
| Direction of rotation [crankshaft] | Counterclockwise viewed from stern | | |
| Dry weight without gear | 585 kg | [1290 lbs] | |
| Emission compliance | EU: RCD 2 | IMO/GL | EMC |
| | US: EPA Tier 3 | | |
| Engine mounting | Rubber type flexible mounting | | |

NOTE:

Fuel condition: Density at 15°C = 0.842 g/cm³; 1HP = 0.7355 kW

*Fuel temperature 40°C at the inlet of the fuel injection pump [ISO 8665]

DIMENSIONS

Rearview

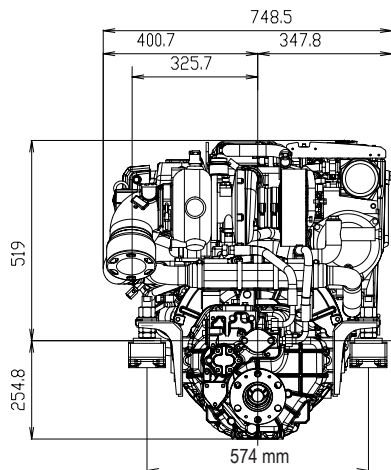

Right side view

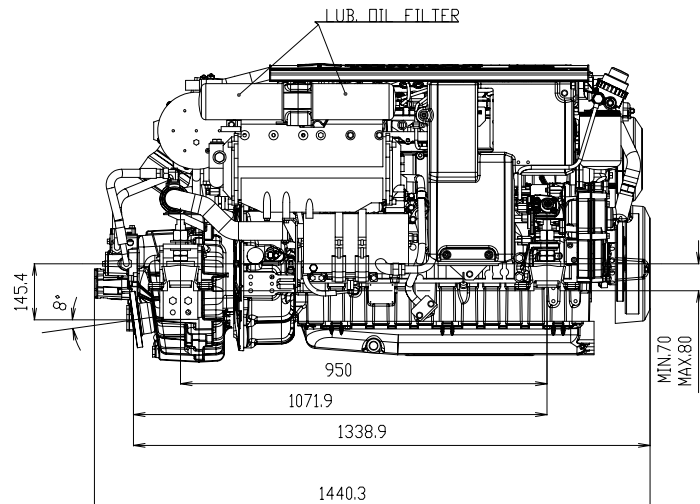

6LY440 with KMH61A2 marine gear

www.yanmarmarine.com



PERFORMANCE CURVES

6LY400

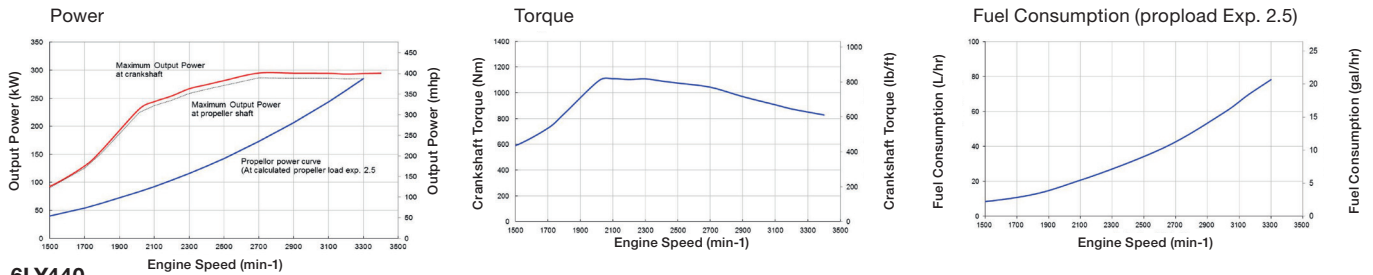

6LY440

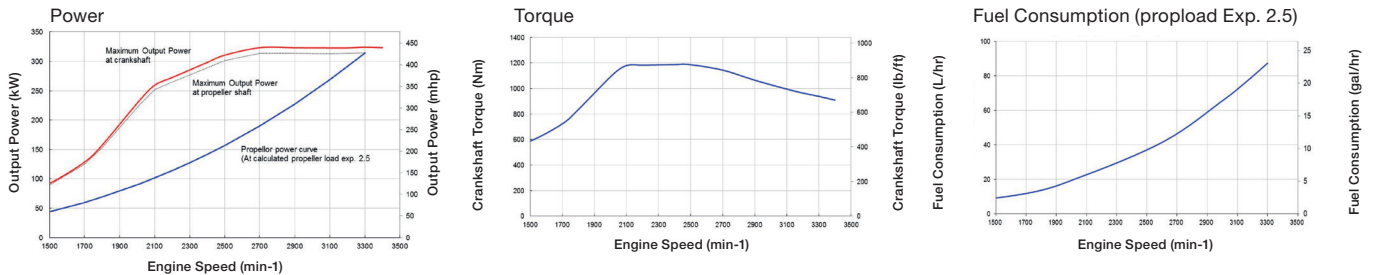

MARINE GEARS / DRIVE*

| Model | KMH61A2 [down angle: 8°] | | | KMH61V2 [V-drive] | | | | ZF280-1 [parallel] |
|---|--|-----------|-----------|--|-----------|-----------|-----------|--|
| Type | Hydraulically actuated multi-disc clutch | | | Hydraulically actuated multi-disc clutch | | | | Hydraulically actuated multi-disc clutch |
| Dry weight** | 81 kg [187 lbs] | | | 113 kg [249 lbs] | | | | 113 kg [249 lbs] |
| Reduction Ratio [fwd/rev] | 1.55/1.55 | 2.04/2.04 | 2.43/2.43 | 1.24/1.24 | 1.49/1.49 | 1.98/1.98 | 2.43/2.43 | Gear ratio's as available from ZF |
| Propeller speed [fwd/rev] | 2129 | 1618 | 1358 | 2661 | 2215 | 1667 | 1358 | |
| Direction of rotation (viewed from stern) | Counterclockwise & Clockwise | | | Counterclockwise & Clockwise | | | | Counterclockwise & Clockwise |
| Dry weight engine and gear/drive** | 666 kg [1468 lbs] | | | 698 kg [1538 lbs] | | | | 698 kg [1538 lbs] |

* Other marine gearboxes and configurations available upon request. Contact your local supplier for more information.
 ** Dry weight including cooler, brackets & damper disk.

ACCESSORIES

Standard engine package

- 2-pole 12V Electric system
- Exhaust/water mixing elbow [L-type]
- Alternator 12V - 125A
- Mounting brackets
- Dipstick on both sides

Optional accessories

- Flexible mounts
- Fuel water separator
- High-riser mixing elbow
- SOLAS kit including certificates
- 24V Secondary Alternator

CONTROL SYSTEM

Standard engine package

- YANMAR CAN-bus control system
- Multi-function color display
- NMEA2000 or J1939 gauge output
- Switch panel
- Back up panel

Optional accessories

- Electronic CAN-bus control-head
- Extension wire harness
- NMEA2000 gauges
- Second or third station

NOTE: All data subject to change without notice. Text and illustrations are not binding.